

LOADING CONDITIONS FOR THE ADSS CABLE:

Note 1:

Generally, the AFL-ADSS cable has an MRCL (Maximum Rated Cable Loading) value in the range of [45%.....63%] RBS (Rated Breaking Strength). Because in the great majority of the cases the MRCL is over 50% RBS, when the user selects "LOADINGS TABLE" from the MAIN MENU , whatever loading case he selects afterwards :Heavy, Medium, Light, California Heavy, California Light (Design Limits: Alcoa, NESC or No Limits), the **DEFAULT CONDITIONS** come with an imposed maximum working tension equal with **50% RBS** in the **first row** (the row referring to the selected loading condition: Heavy, or Medium or Light). Thus, in the great majority of cases, when the MRCL >50% RBS, the maximum tension in the ADSS cable will be lower or equal with the MRCL value, so it's O.K. For the seldom cases when the **MRCL<50% RBS**, due to the fact that the default value is 50%RBS, the program will give you a flag: " **Exceeds the MRCL Limits !**". In this case you go in the **first row** of the "LOADINGS TABLE", from the Main Menu , (the **Heavy, or Medium, or Light condition**) and in the column referring to **TENSION** you change the default value : .5 with **the actual MRCL value, in Lbs., of that particular ADSS cable design** (the program has this facility to let the user introduce the tension in % or Lbs.). Thus, the maximum working tension will be equal with the MRCL of the ADSS cable.

Note 2:

A "Loading Condition" designation comes with a **whole package of default conditions**.

For example, "NESC HEAVY LOAD zone" condition **is not only:**

Temperature	Ice	Wind	Tension	Code	
°F	inches	psf	% or Lbs.	-	
0	.5	4	.5	1	- Initial Tension at Heavy Loading=50% RBS

To this condition are added others:

Temperature	Ice	Wind	Tension	Code	
°F	inches	psf	% or Lbs.	-	
32	.5				- The row for <u>galloping calculations</u> and for " <u>LOADED CURVE</u> " sag template, for <u>ground clearance checking (when the ADSS cable is located close to the lower part of the tower)</u> (you let the row as it is, or change the temperature from 32 °F to 0 °F). If you don't intend to use these, you can delete this row, using "DELETE ROW".
-20					- The row for <u>vibration calculations</u> and for " <u>COLD CURVE</u> " sag template, for <u>uplift checking (when the ADSS cable is located close to the earthwire peak)</u> . If you don't intend to use these, you can delete this row, using "DELETE ROW".
60			.35	1	- Initial Tension at EDS (60 °F)=35% RBS. This is a NESC condition.
60			.25	2	- Final Tension at EDS (60 °F)=25% RBS. This is a NESC condition.
60				2	- The row for CREEP calculations. NEVER DELETE THIS ROW !

Generally, the design condition is the Initial Tension at Heavy Loading (the first row), resulting a maximum working tension lower or equal with the MRCL of the ADSS cable.

However, sometimes , depending on the span length, the program might choose as the design condition the Final Tension at EDS (60 °F)=25%RBS and not the Initial Tension at Heavy Loading=50% RBS (the first row) .

In this case, always, the maximum working tension will be much lower than the MRCL.

However, if you don't want this condition: EDS Final Tension to govern your calculations , but only the Maximum Working Tension Condition (Heavy Loading: the first row) to govern your calculations, you can delete , in "LOADINGS TABLE" Menu, using "DELETE ROW" ,the row:

60			.25	2	
----	--	--	-----	---	--

In this case , the design condition will become **the first row** :

0 .5 4 .5 1

and the maximum working tension will be lower , but closer to, or even equal, with the MRCL of the ADSS cable.

Also, the user can insert, using "INSERT ROW" any other condition required by the customer.

ALUMINUM COMPANY OF AMERICA SAG AND TENSION DATA

EXAMPLE FOR ADSS 0.874": **TRANSMISSION** : RULING SPAN=1335.6 ft.
ACTUAL SPANS:1255, 1325, 1350, 1400 ft; ENGLISH UNITS

ADSS Cable Modulus= 792.1 kpsi MRCL= 4752.0 Lb Tcoef=.00000584 /F

Area= .6000 Sq. In Dia= .874 In Wt= .263 Lb/F RTS= 8360 Lb
English Units

Span= 1335.6 Feet NESC Heavy Load Zone

Creep IS a Factor

Design Points					Final		Initial	
Temp	Ice	Wind	K	Weight	Sag	Tension	Sag	Tension
F	In	Psf	Lb/F	Lb/F	Ft	Lb	Ft	Lb
0.	.50	4.00	.30	1.580	85.24	4156.	84.75	4180.*
0.	.50	.00	.00	1.118	78.23	3200.	77.03	3250.
32.	.50	.00	.00	1.118	78.52	3188.	77.31	3238.
-20.	.00	.00	.00	.263	58.43	1006.	54.23	1084.
0.	.00	.00	.00	.263	58.70	1002.	54.51	1078.
30.	.00	.00	.00	.263	59.12	994.	54.94	1070.
60.	.00	.00	.00	.263	59.54	988.	55.36	1062.
90.	.00	.00	.00	.263	59.95	981.	55.78	1054.
120.	.00	.00	.00	.263	60.36	974.	56.20	1046.

* Design Condition

Maximum Working Tension=4180 < MRCL=4752 [lbs.] O.K.

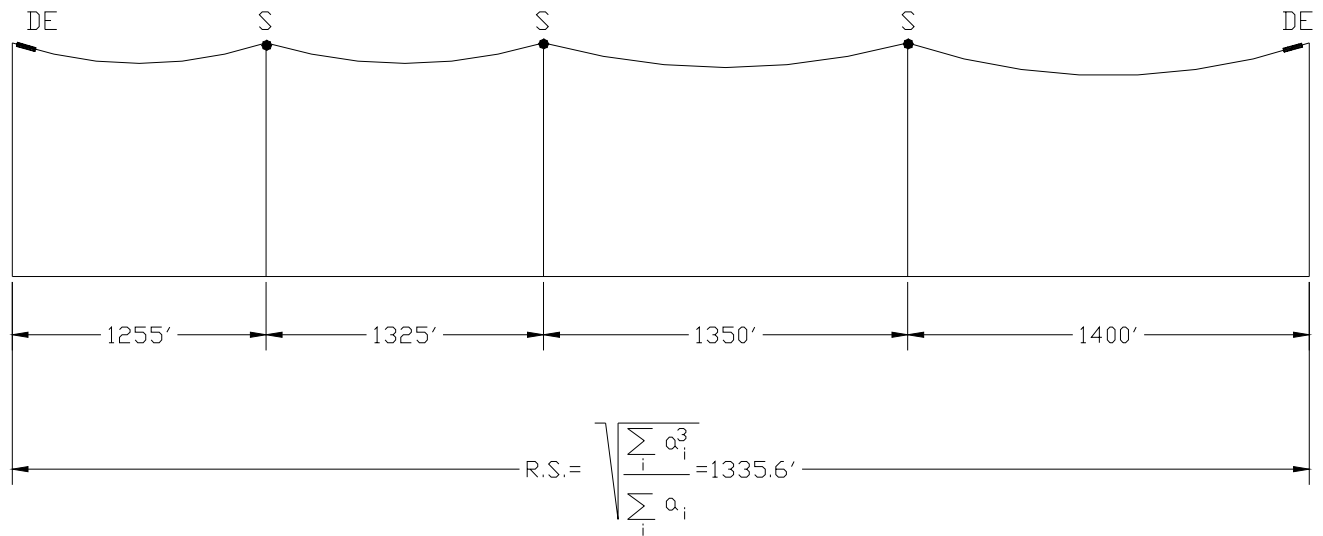

Stringing Sag Table Using Initial Sag Ruling Span: 1335.6 Feet

ADSS Cable Modulus= 792.1 kpsi MRCL = 4752.0 Lb

NESC Heavy Load Zone Max Tension = 4180 Lb

Design: 50.0 % Ult. @ 0. Deg F, .50 In Ice, 4.00 Psf Wind, Initial

H Tens (LBS)	1071.	1068.	1065.	1063.	1060.	1057.	1054.	1052.	1049.	1046.	1044.	1041.	1038.
Temp F>	0.	10.	20.	30.	40.	50.	60.	70.	80.	90.	100.	110.	120.
Sag Feet	48.44	48.57	48.70	48.83	48.95	49.08	49.21	49.33	49.46	49.59	49.71	49.84	49.97
Span Feet	54.01	54.15	54.29	54.44	54.58	54.72	54.86	55.00	55.15	55.29	55.43	55.57	55.71
	56.07	56.22	56.37	56.51	56.66	56.81	56.96	57.10	57.25	57.40	57.54	57.69	57.84
	60.31	60.47	60.63	60.79	60.95	61.11	61.27	61.42	61.58	61.74	61.90	62.05	62.21
Cable Lengths	5354.0	5354.1	5354.3	5354.4	5354.5	5354.6	5354.8	5354.9	5355.0	5355.1	5355.3	5355.4	5355.5

Ruling Span = 1335.6 Feet

↓
EXTREMELY
COLD WINTER
MONTANA

↓
WINTER
NEW YORK

↓
SPRING
AUTUMN
CAROLINA

↓
EXTREMELY
HOT SUMMER
FLORIDA

“Rule of Thumb”: in a DE-DE Section: Constant Installation Tension:

STRINGING DURING WINTER AT 30 °F:

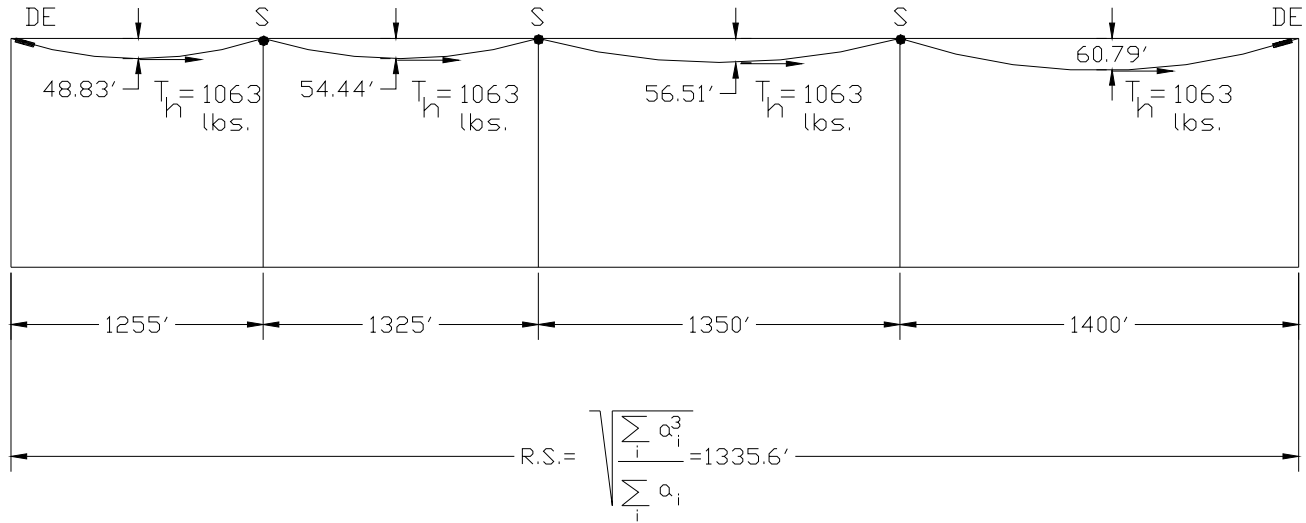

STRINGING DURING SPRING AT 60 °F (EDS):

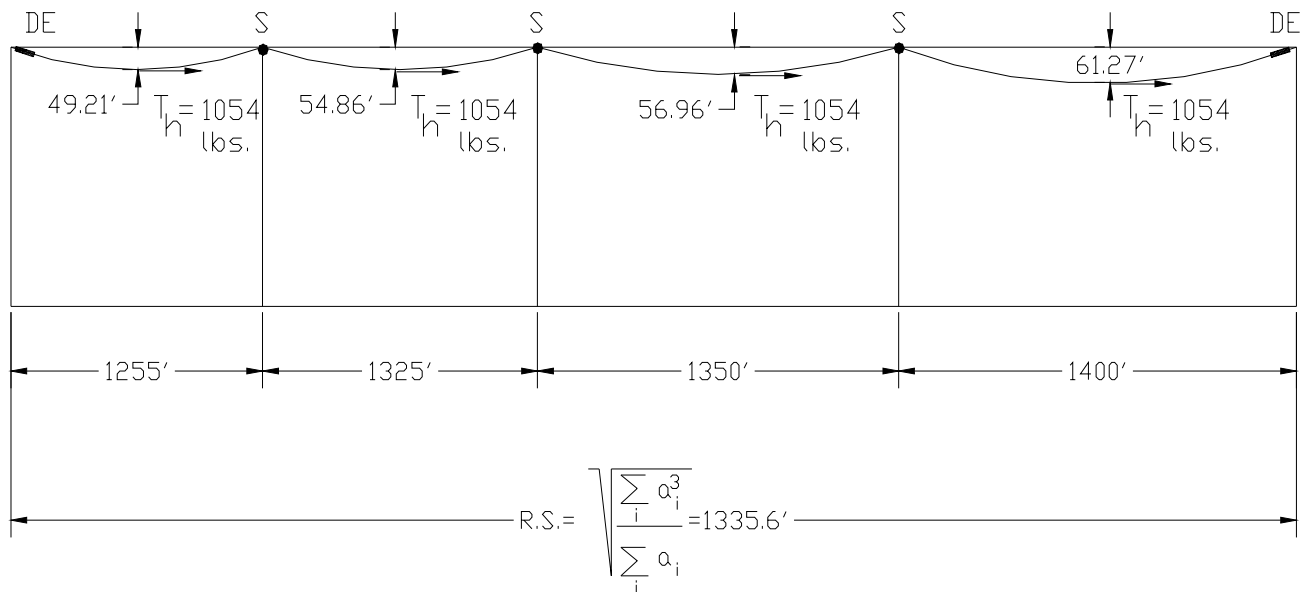

STRINGING DURING SUMMER AT 120 °F:

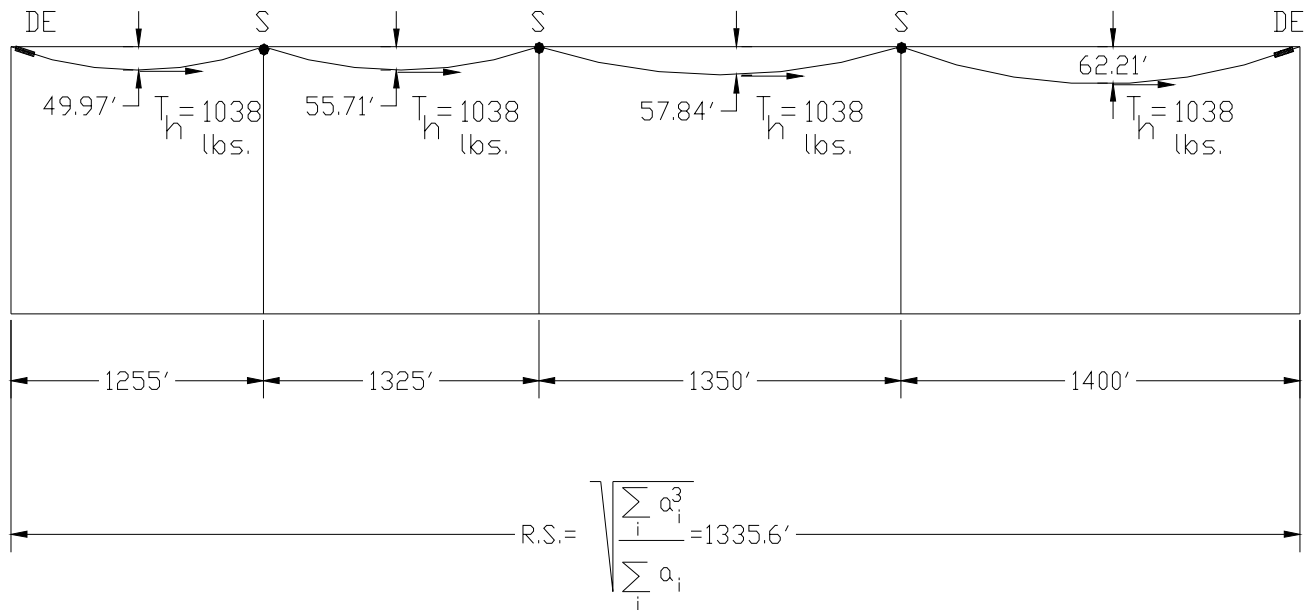

ALUMINUM COMPANY OF AMERICA SAG AND TENSION DATA

EXAMPLE FOR **INCLINED SPAN**: ADSS 0.874": R.S.=1335.6 ft.; DISLEVELMENT=900 ft.
 TRANSMISSION: LOWEST POINT OF THE CATENARY **OUTSIDE** THE 2 STRUCTURES

ADSS Cable Modulus= 792.1 kpsi MRCL= 4752.0 Lb Tcoef=.00000584 /F

Area= .6000 Sq. In Dia= .874 In Wt= .263 Lb/F RTS= 8360 Lb
 English Units

HORIZONTAL: S (NO DISLEVELMENT)

Span= 1335.6 Feet NESC Heavy Load Zone

Creep is NOT a Factor

Design Points				Final		Initial			
Temp	Ice	Wind	K	Weight	Sag	Tension	Sag	Tension	
F	In	Psf	Lb/F	Lb/F	Ft	Lb	Ft	Lb	
0.	.50	4.00	.30	1.580	114.77	3100.	114.77	3100.*	HEAVY NESC : ICE + WIND GROUND CLEARANCE
0.	.50	.00	.00	1.118	110.58	2274.	110.12	2283.	
-20.	.00	.00	.00	.263	101.16	584.	99.48	594.	CHECKING: ICE, NO WIND
0.	.00	.00	.00	.263	101.34	583.	99.66	593.	
30.	.00	.00	.00	.263	101.60	582.	99.93	591.	
60.	.00	.00	.00	.263	101.86	580.	100.19	590.	
90.	.00	.00	.00	.263	102.12	579.	100.46	588.	
120.	.00	.00	.00	.263	102.38	577.	100.72	587.	

* Design Condition

Note 1:

- For the “NESC HEAVY” Condition:

$D_0 = 114.77$ ft. **RESULTING FINAL SAG (NO DISLEVELMENT)**, with components:

HORIZONTAL COMPONENT: 56.00 ft.; VERTICAL COMPONENT=100.19 ft.

These horizontal & vertical values could be obtained running “SAG&TENSION”, after you have selected from the “MAIN MENU”; “OPTIONS”, in “OPTION SETTINGS”, in the row “DISPLAY EXTRA COLUMN”: choose:

Horz & Vert Sag.

- For the “0 °F, 0.5 inch ice, no wind” Condition (used for ground clearance checking) :

$D_0 = 110.58$ ft. **VERTICAL FINAL SAG (NO DISLEVELMENT)**

Note 2: So in order to be sure **you’ll be under the MRCL value**, you’ll respect the following steps:

STEP 1:

Run first “SAG&TENSION” (NO DISLEVELMENT) with an **imposed** horizontal tension: $T_h = 3100$ lbs. This value is chosen **to provoke**, when you are running “INCLINED SPAN” Menu, **vertical tensions at structures (at clamp): T_1 & T_2 less than MRCL=4752 lbs** (approx. 56.8% RBS) at NESC HEAVY.

STEP 2:

Run “INCLINED SPAN” with the data:

- Horizontal Tension: : $T_h = 3100$ lbs at NESC HEAVY (0 °F+0.5” ice+ 4psf wind)
- Weight: $W = 1.580$ lbs./ft. at NESC HEAVY (0 °F+0.5” ice+ 4psf wind)
- CUSTOMER INPUT: Horizontal Span: $S = 1335.6$ ft.
- CUSTOMER INPUT: Elevation Difference: $H = 900$ ft.

Note 3 : You can calculate the dislevelment angle: $\psi = a \tan\left(\frac{900}{1335.6}\right) = 34^\circ$, so results, from the ADSS point of view, a DE-DE span.

Press: **CALCULATE**: results:

$S_1, S_2, S_3 = -549.46$; 1885.06 ; 1217.26 [ft.]

↓

NEGATIVE ⇒ OUTSIDE: THE LOWEST POINT OF THE CATENARY CURVE IS **OUTSIDE** THE 2 STRUCTURES (IF POSITIVE: THE LOWEST POINT OF THE CATENARY **CURVE** WOULD HAVE BEEN **INSIDE** THE 2 STRUCTURES)

$D, D_1, D_2, D_3 = 137.55$; 77.44 ; 977.40 ; 389.87 [ft.]

$T_1, T_2 = 3222.36$; 4644.29 [lbs.]

You check: $T_1 = 3222.36 < MRCL = 4752$ [lbs.] O.K.

$T_2 = 4644.29 < MRCL = 4752$ [lbs.] O.K.

STEP 3:

Run “SAG&TENSION” using:

- Inclined Span: $SL = 1610.51$ [ft.]
- Tension at NESC HEAVY: $P_{AV} = 3824.66$ [ft.] (AVERAGE TENSION)

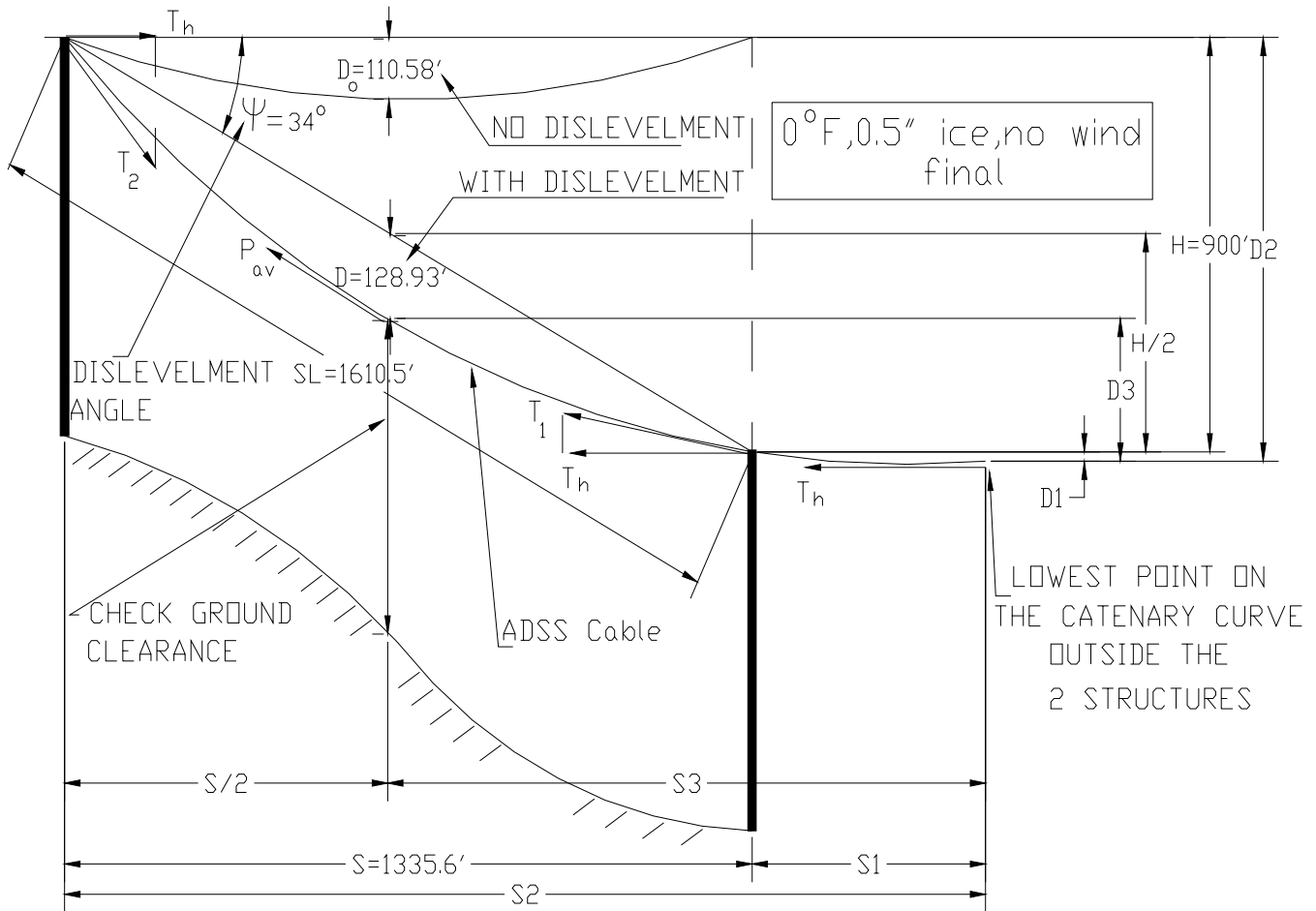

The Program output, for **inclined span** , it's presented on the next page:
 ALUMINUM COMPANY OF AMERICA SAG AND TENSION DATA

EXAMPLE FOR **INCLINED SPAN**: ADSS 0.874": R.S.=1335.6 ft.; DISLEVELMENT=900 ft.
 TRANSMISSION:LOWEST POINT OF THE CATENARY **OUTSIDE** THE 2 STRUCTURES

ADSS Cable Modulus= 792.1 kpsi MRCL= 4752.0 Lb Tcoef=.00000584 /F

Area= .6000 Sq. In Dia= .874 In Wt= .263 Lb/F RTS= 8360 Lb
 English Units

INCLINED SPAN: SL (WITH DISLEVELMENT)

Span= 1610.5 Feet NESC Heavy Load Zone
 Creep is NOT a Factor

Design Points					Final		Initial		
Temp	Ice	Wind	K	Weight	Sag	Tension	Sag	Tension	
F	In	Psf	Lb/F	Lb/F	Ft	Lb	Ft	Lb	
0.	.50	4.00	.30	1.580	135.21	3825.	135.21	3825.*	HEAVY NESC: ICE+WIND GROUND CLEARANCE CHECKING: ICE, NO WIND
0.	.50	.00	.00	1.118	128.93	2834.	128.26	2849.	
-20.	.00	.00	.00	.263	114.17	752.	111.54	769.	
0.	.00	.00	.00	.263	114.39	750.	111.77	768.	
30.	.00	.00	.00	.263	114.73	748.	112.11	765.	
60.	.00	.00	.00	.263	115.06	746.	112.45	763.	
90.	.00	.00	.00	.263	115.40	744.	112.79	761.	
120.	.00	.00	.00	.263	115.73	742.	113.13	759.	

* Design Condition

It will result :

- at “NESC HEAVY” Condition:

$D=135.21$ ft. **RESULTING FINAL SAG (WITH DISLEVELMENT)**, with components:

HORIZONTAL COMPONENT:=65.97 ft.; VERTICAL COMPONENT=118.02 ft.

These horizontal & vertical values could be obtained running “SAG&TENSION”, after you have selected from the “MAIN MENU”->“OPTIONS”, in “OPTION SETTINGS”, in row “DISPLAY EXTRA COLUMN”: choose:

Horz. & Vert. Sag.

- at “0 °F , 0.5 inch ice, no wind ” Condition (used for ground clearance checking) :

$D=128.93$ ft. **VERTICAL FINAL SAG (WITH DISLEVELMENT)**

It can be checked that:

- at “NESC HEAVY” Condition:

Final Tension=3825< MRCL= 4752 [lbs.] O.K.

Final Sag (VERTICAL)=118.02 [ft.] (FOR INCLINED SPAN: SL=1610.5 ft.), compared with: 100.19 ft. (FOR LEVELED SPAN:S=1335.6 ft.)

- at “0 °F , 0.5 inch ice, no wind ” Condition (used for ground clearance checking) :

Final Tension=2834 lbs.

Final Sag (VERTICAL)=128.93 [ft.] (FOR INCLINED SPAN:SL=1610.5 ft.), compared with: 110.58 ft. (FOR LEVELED SPAN:S=1335.6 ft.)

EXAMPLE OF SAG TEMPLATE FOR AN ADSS CABLE:

Generally, the sag template is a scaling device used for structure spotting and shows the vertical position of phase conductors, groundwires (OPT-GW) or ADSS cables for specified design conditions. It is used on plan-profile drawings to determine graphically the location and height of supporting structures required to meet line design criteria for vertical clearances, hardware swing, and span limitations. Generally, the phase conductor curves control the line design. The sag template for the groundwires (OPT-GW) and for the ADSS cable is used to show its (their) position in relationship to the phase conductors ,and ground, for special spans.

In the case of the ADSS cable, it’s location establishes what type of sag template to be used:

- For ADSS cable located close to the lower part of the tower, it’s “**LOADED CURVE**”(or, very seldom, in zones with no ice: ”**HOT CURVE**”) sag template it’s used to check the minimum ground clearance.
- For ADSS cable located close to the earthwire peak, it’s “**NORMAL CURVE**” and “**HOT CURVE**” sag templates are used to check clearance to phase conductors, and “**COLD CURVE**” sag template to check for uplift conditions.

The sag template should include the following sag curves based on the design ruling span:

1. **“COLD CURVE”** : Minimum temperature, no ice, no wind, initial sag curve.
Used to check for uplift and hardware swing.
Example: -20 ° F (or 0 ° F), bare wire, INITIAL
2. **“NORMAL CURVE”**: Everyday temperature, no ice, no wind, final sag curve.
Used to check normal clearances and hardware swing.
Example: 60 ° F, bare wire, FINAL

3. **“HOT CURVE”:** Maximum operating temperature = Max. ambient temperature, no ice, no wind, final sag curve.
Used to check for minimum vertical clearances.
Example: 100° F (or 120 ° F), bare wire, FINAL
4. **“LOADED CURVE”:** Icing Temperature, with ice, no wind, final sag curve.
Used to check for minimum vertical clearances.
Example: 0 ° F (or 32 ° F) , ice load, no wind, FINAL

NOTE 1: The **maximum sag** between the “HOT CURVE” and the “LOADED CURVE” will be used to **check for minimum vertical clearances.** Generally, for ADSS cables, the “LOADED CURVE” gives the maximum sag, so, in the great majority of cases, the “LOADED CURVE” will be used to check minimum vertical ground clearances. (Only for zones with no ice, the “HOT CURVE” will be used).

NOTE 2: If in the “Loading Table” **are not presented one of the above conditions**, you may add them all, or only just those you need, by using command “ Insert Row”.

Example: You have selected “**Heavy NESC**” load, and you want to **check the minimum vertical ground clearance of an ADSS cable :**

STEP 1: You add (using “**Insert Row**”) only the row corresponding to the “**LOADED CURVE**”:

Temperature ° F	Ice inches	Wind psf	Tension % or Lbs.	Code -
0	0.5			

STEP 2: You run “**SAG&TENSION**” .

STEP 3 : You run “**SAG CURVES**” selecting the **above row from the “Conductor Data” Menu, Final Sag, Catenary, Scale (the international standard values):** Vert: 1 inch =20 ft.; Horz: 1 inch =200 ft. **Also you can add the required ground clearance.**

Example: ADSS cable, design .874” diameter, required ground clearance=20 ft., ruling span=1336 ft., the final “Loaded curve” is characterized by the following data (having as **design condition: 0.5% R.B.S.=4180 lbs at Heavy NESC**):

- **final horizontal** tension at: **0 ° F+0.5” ice, no wind:** $T_h = 3156 \text{ lbs.}$
- **final average** tension at: **0 ° F+0.5” ice, no wind:** $P_{AV} = 3200 \text{ lbs.}$
- weight at: **0 ° F+0.5” ice, no wind:** $W = 1.118 \text{ lbs./ft.}$
- catenary constant: $C = \frac{T_h}{W} = \frac{3156 \text{ lbs.}}{1.118 \text{ lbs/ft.}} = 2823 \text{ ft.}$

The sag template ,with or without gridlines, could be seen on the screen or it can be saved as an .DXF file. Afterwards, this .DXF file can be imported in AUTOCAD R13 using FILE-IMPORT command and SAVED AS a .DWG file. This file could then be imported in any WORD .DOC file using the command INSERT-OBJECT-AUTOCADR13-CREATE FROM FILE-BROWSE, and then select the file:

